



magswitch[®]

Changing the way things are done.





Heavy Lifting Solutions Pg 29



8100747

Magswitch

Magswitch Technology, headquartered in Colorado, USA is a leader in switchable magnetic technology. From initial development, design and engineering to manufacturing, final delivery and distribution, Magswitch has paved the way for innovation in multiple industries across the globe.

Magswitch has evolved from manufacturing magnetic tools to engineering innovative technology to increase safety, productivity and speed in industries such as welding, fabrication, automation, manufacturing, heavy industry, woodworking and more.

With numerous patents and patents pending in all industrialized markets across the globe, Magswitch has evolved into an global integrated business. We are committed to a business model that identifies key industry partners, allowing the corporation to leverage its technology and products through recognized global distributors.

but first



We consider safety in everything we do. If you work around steel, safety is the first consideration. Fewer hands on the job touching steel, means a safer workplace. Safety is crucial to our products - easy actuation, lighter lifting, stability control and lift-to-shear capabilities all tie back to an emphasis on safety.

7 Worldwide Magswitch Locations

65+ Patents/ Patents Pending

250+ Unique Magswitch Solutions

1000+ Worldwide Magswitch Dealers

Changing The Way Things Are Done.

"The Magswitch management team is made up of visionary leaders and enthusiastic youth who constantly strive for innovation within a "can-do" culture. The key to our success is our love for competition, as this is what is imprinted in our DNA."



8100364

Catalog Guide



- 3** Welding & Heavy Fabrication
- 13** Drilling
- 15** Material Handling & Alignment
- 19** Lifting Tools & Frames
- 27** New To Magswitch: ELAY Series
- 29** Heavy Lifting Solutions
- 31** Woodworking
- 35** Custom Products
- 37** Application Services
- 39** Automation



Every Magswitch product is proudly developed, manufactured and tested by Magswitch to ISO 9001:2015 standards.



Safety is our primary design consideration. We focus on reducing accidents and injuries in workplaces.

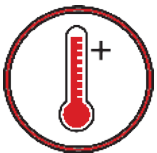

Look for our high heat tools. Magswitch tools are capable of handling up to 742° Fahrenheit (350° Celsius).



Magswitch products are a green technology utilizing the enduring power of rare earth magnets with low energy consumption.



Technology That Attracts.™

magswitch.com | +1 (303) 468.0662

WELDING & HEAVY FABRICATION

Changing The Way Welding & Fabrication is done!

At Magswitch, our Welding & Heavy Fabrication tools are engineered to drive productivity for professional welders and fabricators. Large sheet leveling, sheet de-stacking, fixturing, weld grounding, mounting, workholding, positioning, fitting and many more applications are performed significantly faster with our products. The true ON and OFF capabilities of Magswitch tools create a platform that is more efficient, faster, safer and easier to us!

Product Lineup

- MagSquares
- Ground Clamps
- MagWheels
- MagTethers
- MagMounts
- Angle Tools
- MagHooks
- MagYoke



8100238



Customer Review

MagSquare 400

The MagSquare 400 is a high-quality product. The magnet is very strong. I used three of them to make a mag base for my laser tracker. My base cost me a fraction of the price and its way more powerful than the mag bases on the market.



8100438

Grinding with Multi Angle 400



8100495

Angled Positioning with 90 Degree Angle 600



8100367

Fixturing with Pivot Angle 200



8100099

Fabricating/Cutting with MagSquare 1000

MagSquares

Applications: Fixturing, Workholding, Mounting

Magswitch magnetic squares are the most versatile workholding and fixturing tool ever! Align and secure flat or round pieces of steel to fabricate angles. Pull corners, secure steel for cutting, use as a guide, make your own fixtures and more with our MagSquares.

- Multiplane magnetic grip on 5 sides
- Machined at 90-degrees with pre-tapped holes for mounting
- Mounts anywhere - no limitations like clamps
- Magnet turns completely On and Off
- Magnet stays clean as it is easy to wipe debris off
- Does not require an electrical power source
- Holds flat and round surfaces of steel

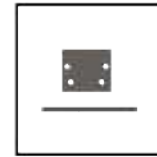

FLAT

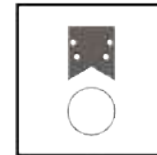

ROUND



High Heat Available
Upon Request



	MagSquare 1000	MagSquare 600	MagSquare 400	MagSquare 165
Part #	8100099	8100106	8100238	8100494
Max Breakaway	1052 lbs (477 kg)	607 lbs (275 kg)	399 lbs (181 kg)	150 lbs (68 kg)
Height	5.8 in (146.9 mm)	4.1 in (105.4 mm)	3.6 in (90.3 mm)	2.5 in (64.3 mm)
Width	2.8 in (72 mm)	2 in (51.5 mm)	1.6 in (41.3 mm)	1.2 in (31 mm)
Length	4.3 in (108 mm)	3 in (75 mm)	2.5 in (64 mm)	1.9 in (48 mm)
Weight	7.9 lbs (3.6 kg)	3.1 lbs (1.4 kg)	2.0 lbs (0.9 kg)	0.7 lbs (0.3 kg)

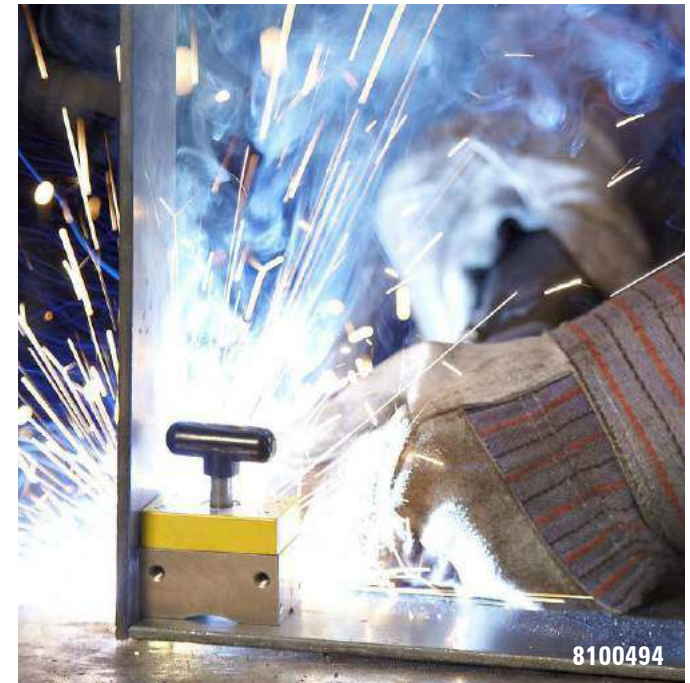

8100494



8100106



8100552



8100746

Ground Clamps

Applications: Grounding, Welding

Magswitch magnetic ground clamps come with the new fin design which lowers temperature. With our ground clamps, no more tacking necessary. Simply place our magnetic ground clamp on a clean work surface, turn on and start welding!

- Fast setup as it instantly grounds to flat and round surfaces of steel
- Stronger hold in the shear (vertical) position allows for use with heavy gauge cable
- No more tacking on tabs and searching for ground location
- New fin design lowers temperature by 27%.
- Magnet turns completely On and Off
- Magnet stays clean as it is easy to wipe debris off
- Does not require an electrical power source



FLAT



ROUND



	800 Amp Ground Clamp	600 Amp Ground Clamp	300 Amp Ground Clamp
Part #	8100552	8100747	8100746
Max Breakaway	300 lbs (136 kg)	200 lbs (89 kg)	90 lbs (41 kg)
Height	2.9 in (73.9 mm)	2.6 in (65.5 mm)	2.3 in (57.3 mm)
Width	3.9 in (98.6 mm)	3.1 in (78.5 mm)	1.9 in (49 mm)
Length	4.9 in (125.6 mm)	4.2 in (105.6 mm)	2.9 in (73.1 mm)
Weight	3.5 lbs (1.6 kg)	1.8 lbs (0.8 kg)	0.9 lbs (0.4 kg)

MagWheels

Applications: Fitting, Positioning, Guiding, Fixturing, Pipe Handling

Magswitch magnetic wheels have a powerful connection to drive units on any ferrous surface enabling flat, vertical or inverse travel. Ideal for positioning and guiding, sheet feeding, pipe handling, fitting and fabrication, and numerous OEM automation and fixturing applications.

- Magnetic rotating elements with potential to automate
- Non-marring hold
- Can be fitted with drive units for mobile applications
- Climbing, carrying and driving anywhere above/below magnetic surface
- Magnet turns completely On and Off
- Magnet stays clean
- Does not require an electrical power source
- Holds to flat and round surfaces of steel

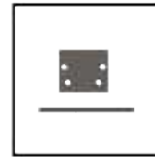

FLAT

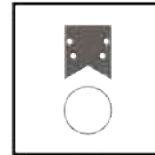

ROUND



	MagWheel 1000	MagWheel 600	MagWheel 150	MagWheel 95
Part #	8100250	8100075	8100074	8100401
Max Breakaway	528 lbs (239 kg)	292 lbs (132 kg)	65 lbs (29 kg)	38 lbs (17 kg)
Height	6.9 in (175 mm)	4.8 in (121.7 mm)	2.8 in (71.2 mm)	2.2 in (55.7 mm)
Width	5 in (127 mm)	3.6 in (92 mm)	2 in (52 mm)	1.6 in (41 mm)
Length	7.1 in (180.4 mm)	4 in (101 mm)	2.7 in (67.8 mm)	2.2 in (56.3 mm)
Weight	19.8 lbs (9 kg)	6.6 lbs (3 kg)	2.2 lbs (1 kg)	0.7 lbs (0.3 kg)

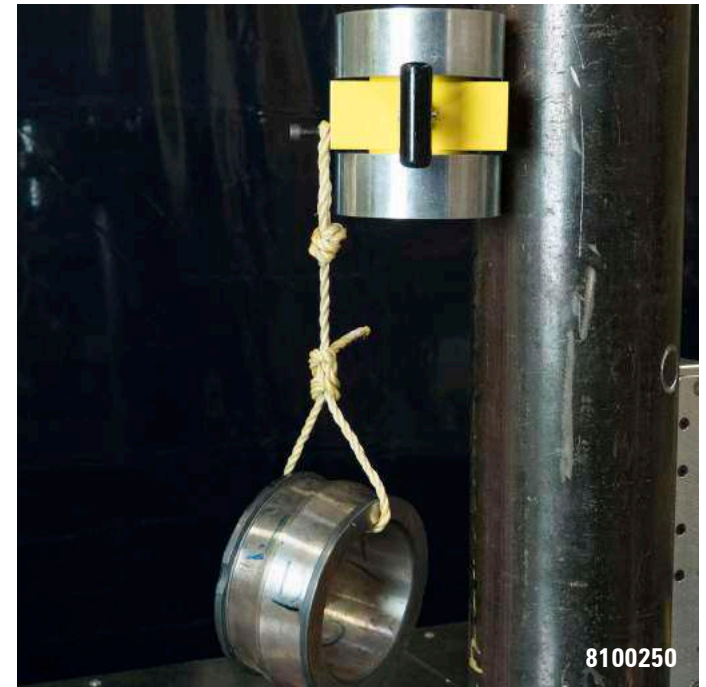



8100523



8100451

MagMounts

Applications: Mounting, Hanging

Magswitch MagMounts allow for easy movement and placement of a tool. With a single On and Off lever, you have strong magnetic hold force at your disposal. The top of the tool is ready for mounting a variety of accessories.

- Fixed bar magnet is for flat steel
- Swivel bar magnet is for round or uneven shapes
- Multiple threaded holes on the top
- Perfect for top mount tools, measuring and security devices
- Magnet turns completely On and Off
- Magnet stays clean
- Does not require an electrical power source
- Holds flat and round surfaces of steel

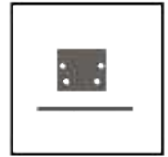

FLAT



ROUND



High Heat Available
Upon Request



	MagMount 600	MagMount 400	MagMount 300	MagMount 235	MagMount 150
Part #	8100580	8100523	8100595	8100451	8100579
Max Breakaway	522 lbs (237 kg)	420 lbs (191 kg)	246 lbs (111 kg)	216 lbs (98 kg)	104 lbs (47 kg)
Height	2.8 in (71 mm)	2.6 in (65 mm)	1.7 in (44 mm)	1.7 in (44.2 mm)	1.6 in (40 mm)
Width	4.1 in (104.4 mm)	3.2 in (82.3 mm)	4.1 in (104.4 mm)	3.75 in (95 mm)	2.2 in (55.4 mm)
Length	4.7 in (120 mm)	4.6 in (116 mm)	5.3 in (135 mm)	2.1 in (53.3 mm)	3.1 in (78.4 mm)
Weight	3.5 lbs (1.6 kg)	2.4 lbs (1.1 kg)	2 lbs (0.9 kg)	1.2 lbs (0.6 kg)	0.9 lbs (0.4 kg)

MagTethers

Applications: Underwater Tethering, Welding, Oil & Gas, Military

Magswitch MagTethers help you tether you or your equipment while working above and below water. Our MagTether is sealed with a marine grade corrosion resistant coating to hold up to saltwater.

- Safety latch to turn On and Off
- Quick connect and disconnect
- Alongside and below the surface mooring
- Noise suppressing coating
- Ideal for underwater tethering, military and commercial oil and gas applications.
- Magnet turns completely On and Off
- Magnet stays clean
- Does not require an electrical power source

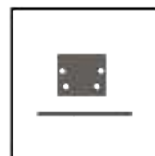

FLAT

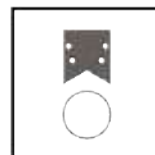

ROUND



8100051



	MagTether 1000	MagTether 600	MagTether 300
Part #	8100051	8100077	8100111
Max Breakaway	1052 lbs (477 kg)	607 lbs (275 kg)	247 lbs (112 kg)
Height	6 in (153.4 mm)	5 in (127.3 mm)	4.2 in (107.3 mm)
Width	6.2 in (158.3 mm)	4.9 in (124.4 mm)	4.9 in (124.4 mm)
Length	7.6 in (194 mm)	6.3 in (161 mm)	6.5 in (164 mm)
Weight	10 lbs (4.6 kg)	4 lbs (1.8 kg)	2.2 lbs (1 kg)



8100077

Mini Angles

Applications: Fixturing, Welding

Mini Angles are our magnetic workholding tool with multiple angles in one! They offer a wide range of angles: 45/135°, 60/120°, 75/105° and 90° angles. Extremely versatile welding and fabrication angle tools.

- Accommodates flat sheets and pipes
- Offers several common angles
- Sturdy and compact
- Magnet turns completely On and Off
- Magnet stays clean
- Does not require an electrical power source
- Holds flat and round surfaces of steel

Pivot Angles

Applications: Fixturing, Welding

Magswitch magnetic pivot welding angles offer a range of angles from 20 to 270 degrees with 5 degree indicators and detents. Two sides of the tool magnetize when turned on and can be secured to a table or wall to hold a fixture in place.

- Single lock at the elbow to secure your angle
- Dial on elbow has indicators every 5 degrees
- Detents at every 45 degrees for rapid adjustment
- Magnets turn completely On and Off
- Magnets stay clean
- Does not require an electrical power source
- Holds flat and round surfaces of steel

MagVises

Applications: Fixturing, Welding

Magswitch MagVises that you don't have to bolt in place! Perfect for drilling, cutting, grinding and beveling small to medium size pieces. Switch On/Off for magnetic hold force by rotating the knob. When you're done, just carry it to where it's needed next.

- Offers 45/135° + 60/120° + 75/105° + 90° angles
- Doubles as a multi-angle work holding tool
- Vise options include round, angle stock, square bar or flat
- Magnet turns completely On and Off
- Magnet stays clean
- Does not require an electrical power source
- Holds flat and round surfaces of steel

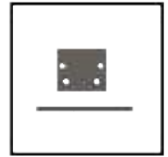

FLAT



ROUND



	Mini Angle 400	Mini Angle W/ 200 Amp Ground	Mini Mutli Angle	Mini Angle	Pivot Angle 150	Pivot Angle 200	MagVise 1000	MagVise 1500
Part #	8100438	8100351	8100350	8100352	81001215	8100367	8100450	8100897
Max Breakaway	205 lbs (93 kg)	76 lbs (34 kg)	76 lbs (34 kg)	76 lbs (34 kg)	130 lbs (59 kg)	215 lbs (98 kg)	413 lbs (187 kg)	788 lbs (357 kg)
Height	3.8 in (95.5 mm)	3.4 in (86.3 mm)	2.6 in (65.7 mm)	2.1 in (53.7 mm)	8.3 in (210 mm)	1.75 in (44.45 mm)	5.4 in (138 mm)	6.3 in (161 mm)
Width	2.6 in (65 mm)	1.7 in (42 mm)	1.3 in (32 mm)	1.3 in (32 mm)	2.9 in (72.5mm)	2.75 in (70 mm)	4.3 in (110 mm)	6 in (152.7 mm)
Length	5.1 in (129 mm)	3.6 in (90.5 mm)	2.8 in (72.3 mm)	2.3 in (59.5 mm)	8.3 in (210 mm)	15 in (38 mm)	5.9 in (149.8 mm)	7.1 in (179.7 mm)
Weight	2.6 lbs (1.2 kg)	0.9 lbs (0.4 kg)	0.4 lbs (0.2 kg)	0.4 lbs (0.2 kg)	3.2 lbs (1.5 kg)	3.6 lbs (1.63 kg)	9.7 lbs (4.4 kg)	21.2 lbs (9.6 kg)



90 Degree Angles

Applications: Fixturing, Welding

Magswitch 90 Degree Angles deliver superior accuracy, efficiency and speed at a fixed 90-degree welding angle. Simply adjust the MagSquares by sliding them up or down on each axis for unmatched versatility.

- Lightweight with incredible strength
- Precision positioning
- MagSquares can be reversed on each axis
- Magnets turn completely On and Off
- Magnets stay clean
- Does not require an electrical power source
- Holds to flat and round surfaces of steel

BoomerAngles

Applications: Fixturing, Welding

Magswitch BoomerAngles feature a rotating MagSquare at each axis which provides virtually unlimited angles including a pre-set for 90-degree holding. Easy On and Off by rotating the black knobs.

- Adjustable angle holds
- Position for odd angles in seconds
- Non-marring hold
- Magnets turn completely On and Off
- Magnets stay clean
- Does not require an electrical power source
- Holds flat and round surfaces of steel



FLAT



ROUND

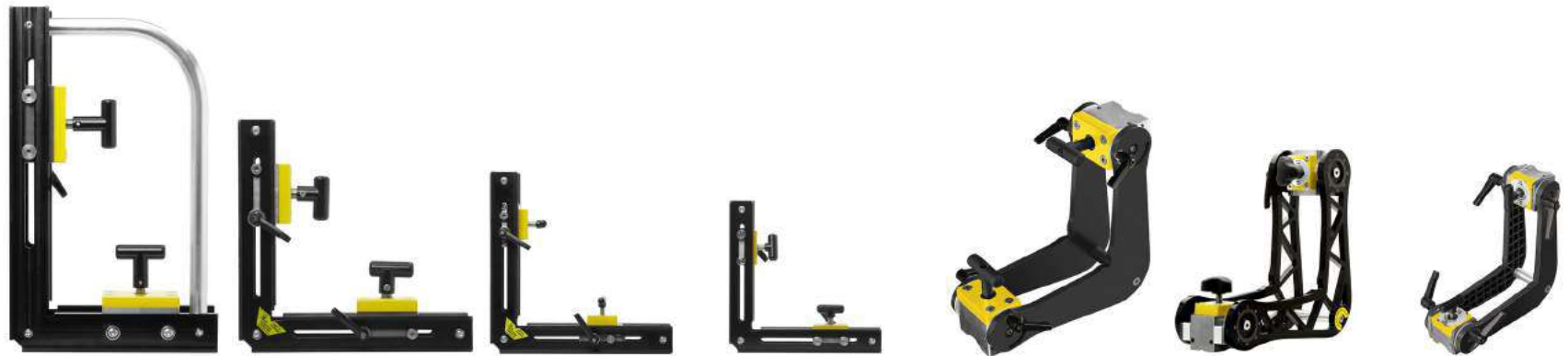

	90 Degree Angle 1000	90 Degree Angle 600	90 Degree Angle 400	90 Degree Angle 165	Boomer Angle 600	Boomer Angle 400	Boomer Angle 150
Part #	8100503	8100495	8100454	8100548	8100090	8100453	8100091
Max Breakaway	1052 lbs (477 kg)	607 lbs (275 kg)	401 lbs (182 kg)	122 lbs (55 kg)	607 lbs (275 kg)	205 lbs (93 kg)	109 lbs (49 kg)
Height	11.2 in (287 mm)	11.2 in (287 mm)	11.2 in (287 mm)	8.1 in (205 mm)	10.1 in (257.5 mm)	10 in (254 mm)	7.5 in (190.5mm)
Width	5.8 in (146.6 mm)	3.9 in (100 mm)	3.5 in (89.3 mm)	3 in (76.8 mm)	6.5 in (164.3 mm)	2.6 in (66 mm)	3 in (76.2 mm)
Length	18.7 lbs (474 mm)	11.2 in (287 mm)	11.2 in (287 mm)	8.1 in (205 mm)	10.1 in (258 mm)	11 in (279.4 mm)	7.5 in (190.5 mm)
Weight	10.2 lbs (4.6 kg)	8.2 lbs (3.7 kg)	6.2 lbs (2.8 kg)	1.8 lbs (0.8 kg)	9.7 lbs (4.4 kg)	7 lbs (3.1 kg)	2.7 lbs (1.3 kg)

MagHooks



Applications: Utility Hooks, Welding, Fabricating

Need a helping hand? Organize your workspace with our magnetic hook by hanging tools, lights, wires, cables and more.

- Instantly attaches to flat and round surfaces
- Locking hand for safety
- Lightweight and reliable
- Convenient and easily move from job to job
- Magnet turns completely On and Off
- Magnet stays clean
- Does not require an electrical power source



	Mag-Utility Hook 40	Mag-Utility Hook 25
Part #	8100006	8100012
Max Breakaway	202 lbs (92 kg)	115 lbs (52 kg)
Height	4.1 in (103 mm)	3.5 in (89.3 mm)
Width	2.7 in (69 mm)	1.6 in (40 mm)
Length	2.7 in (69 mm)	1.9 in (47.4 mm)
Weight	1.8 lbs (0.8 kg)	0.4 lbs (0.2 kg)

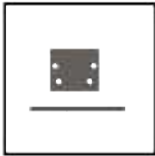

FLAT

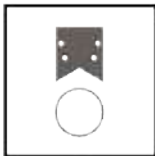

ROUND

MagYoke

Applications: Weld Joints, Magnetic Particle Inspection

The permanent magnetic Yoke gives the user the ability to perform magnetic particle inspection without an electrical power source. It has all the advantage of a permanent Yoke system without the problems related to adhesion of metal particles.

- Non-destructive testing of weld joints
- Full yoke system testing capabilities
- Using patented ON-OFF switchable magnets, test welds without an electrical power source
- OFF position allows tool to easily be removed from material
- Significantly reduces metal to metal sparking
- Lightweight and compact



	MagYoke
Part #	8100551
Max Breakaway	97 lbs (44 kg)
Height	6.5 in (165 mm)
Width	1.5 in (38 mm)
Length	5.5 lbs (139.7 kg)
Weight	6 lbs (2.7 kg)

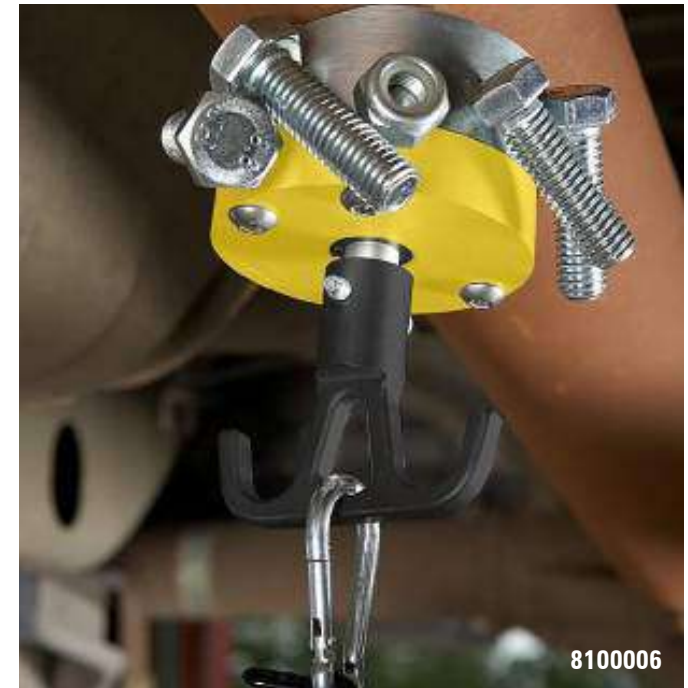

8100006



8100551

DRILLING & TAPPING

Changing The Way Drilling & Tapping is done!

Magswitch magnetic drills drive speed, productivity and safety, all in one. It is built with safety in mind. Our patented magnets do not require power to turn ON and OFF. In event of power failure, the Magswitch magnetic base will not fall. MagDrills feature superior performance on a wide range of steel and work well with flat and contoured surfaces.

Product Lineup

- MagDrill Disruptor 30
- MagDrill Disruptor 55

Coming Soon

- Low Profile Compact Drill
- MagDrill Disruptor 43



Customer Review **MagDrill Disruptor 30**

I work in solar construction and used this drill to cut 7/8" holes in over 200 galvanized steel pile. This drill never over heated, never let me down, and could drill through 3/8" steel with easy when using a lubricant and coolant liquid. The magnets are strong enough to hold even if they are not on a flat surface. I could not have completed my project without this tool.

8100920



81001155

Multi Surface Drilling with Disruptor 55



8100920

Pipe Drilling with Disruptor 30



81001155

Tapping with Disruptor 55



81001240

Vertical Drilling with Disruptor 43

MagDrills

Applications: Welding, Fabricating, Horizontal & Vertical Drilling, Tapping

The next evolution in magnetic drilling. Our MagDrill Disruptor series offers superior magnetic performance on a wide range of steel-flat or curved surfaces.

- No electricity is needed for the magnets; all the power goes to drill alone
- During the loss of power and the drill remains in place
- Our powerful 'shallow-field' technology allows the drill to hold strong on thick or thin steel
- Patented pending base magnets swivel eliminates the need for expensive adapters
- The base magnets can be 'partially actuated' in order to slide the drill in place for cleaning and hole inspection without removing the drill

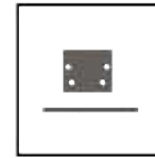

FLAT

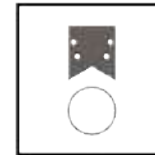

ROUND



81001155



	MagDrill Disruptor 55	MagDrill Disruptor 43	MagDrill Disruptor 30
Part #	81001155	81001240	8100920
Max Breakaway	1512 lbs (686 kg)	1172 lbs (532 kg)	1172 lbs (532 kg)
Height	27 in (688 mm)	21 in (533.4 mm)	16.4 in (416 mm)
Width	9.4 in (238.7 mm)	10 in (254 mm)	7.3 in (185 mm)
Length	11.5 lbs (291.5 kg)	11 in (280 mm)	10.8 in (275 mm)
Weight	39 lbs (17.6 kg)	26.2 lbs (11.9 kg)	24.2 lbs (11 kg)



8100920

MATERIAL HANDLING & ALIGNMENT

Changing The Way Material Handling is done!

Magswitch products are designed to handle flat, round, pipe, hot and dirty steel safely. Our material handling and alignment products drive speed, efficiency and productivity in shipyard applications, city jobs such as lifting manhole covers or valve boxes, underwater jobs such as tethering or welding etc. The simple ON and OFF patented magnetic technology makes everyday steel handling jobs faster and safer.

Product Lineup

- Extenda-Lifts
- MagDolly
- MagPress
- Beam Jacks
- 90 Degree Angle Stiffener
- 90 Degree Angle 1000
- MagVises

8100361



Customer Review *Sheet Handler*

With the Magswitch Sheet Handler, no more pounding, breaking, grinding or clamping to level steel. Just turn the magnet on and pull the lever up to align.



Sheet Alignment with MagPress



Grinding with MagVise 1000



Stiffener Positioning with 90 Degree Angle 1000



Lifting Manhole Cover with MagDolly

Extenda-Lifts

Applications: Lifting Valve Box, Lifting Small Lids, Infrastructure and Utility Jobs

Pick up and move steel without bending over and using your hands. Twist the handle to turn On/Off 600 or 1000 pounds of magnetic hold force. Safely lift a valve box with ease as well as hot, sharp or dirty steel without touching it.

- Instantly attaches to and removes valve box covers
- Our safety lock keeps magnets on until they're turned off
- Precise positioning
- Lightweight and compact
- Ideal for cities and utilities, valve box and small lid removal
- Magnet turns completely On and Off
- Magnet stays clean as you can wipe off debris easily
- Does not require an electrical power source



	Extenda-Lift 1000	Extenda-Lift 600	MagDolly
Part #	8130177	8100025	8100433
Max Breakaway	1052 lbs (477 kg)	478 lbs (217 kg)	350 lbs (159 kg)
Height	29.3 in (744.2 mm)	28.2 in (716.5 mm)	54.5 in (1385 mm)
Width	5 in (127 mm)	3.9 in (100 mm)	13.7 in (348.6 mm)
Length	5 in (127 mm)	4 in (102.3 mm)	76.3 in (1938.3 mm)
Weight	9.7 lbs (4.4 kg)	5.3 lbs (2.4 kg)	57 lbs (25 kg)

MagDolly

Applications: Lifting Manhole Covers, Infrastructure and Utility Jobs

Our collapsible dolly has 2 solid rubber wheels and is designed to lift and carry heavy sheets, pipes or any steel objects. No more getting down on your knees or pinching your fingers to move heavy manhole covers.

- Safer for your back, knees, and hands
- Allows one person to move heavy objects
- Fast and easy setup
- Sturdy and reliable
- Maintains control and stays clean
- Maneuvers on uneven surfaces
- Does not use an electrical power source
- Compatible with lifting magnets, sold separately



8130177



8100433

MagPress

Applications: Sheet Alignment, Leveling, Shipbuilding

Magswitch MagPress aligns large steel sheets with precision. Equalize high and low points between steel gaps by placing the magnet on low, pry on high and weld.

- Instantly attaches to flat and round surfaces
- Lightweight and compact
- Turn the handle to the side and this tool becomes a beam press which can press a 4-6" beam
- Magnet turns completely On and Off
- Magnet stays clean as you can wipe off debris easily
- Does not require an electrical power source



Beam Jacks

Applications: Shipbuilding, Closing gaps in Weldments, Leveling, Bending

The Magswitch Aluminum adjustable Beam Jacks are suited to pulling ferrous steel flat against stiffener beams, eliminating air gaps to allows for more efficient welding.

- Instantly attaches to flat and round surfaces
- Lightweight and performs better on thin materials
- Removes air gaps between structural members and base materials
- Magnet turns completely On and Off
- Magnet stays clean as you can wipe off debris easily
- Does not require an electrical power source



90 Degree Angle Stiffeners

Applications: Shipbuilding, Fixturing at 90 Degree Angle, Welding

Magswitch Stiffeners are designed for some serious power, stabilization and precision control for those heavy-duty jobs. The entire side plate is magnetized when turned on.

- Mounts to flat and round surfaces of steel
- Reinforced end caps for superior durability
- Lightweight with incredible strength
- Precise positioning
- Magnet turns completely On and Off
- Magnet stays clean as you can wipe off debris easily
- Does not require an electrical power source

	MagPress	1.5 Ton Beam Jack	3 Ton Beam Jack	6 Ton Beam Jack	90 Degree Angle Stiffener 2400	90 Degree Angle Stiffener 1200
Part #	8100935	81001245	8800605	81001171	81001000	8100961
Breakaway	1024 lbs (465 kg)	3304 lbs (1499 kg)	6887 lbs (3124 kg)	12203 lbs (5535 kg)	680 lbs (308 kg)	293 lbs (133 kg)
Height	7.5 in (190.5 mm)	20.7 in (525.8 mm)	34.7 in (881 mm)	34.9 in (887.7 mm)	12.3 in (312.8 mm)	8.2 in (208 mm)
Width	5.75 in (146 mm)	21 in (533.4 mm)	21 in (535.3mm)	25.1 in (637.5 in)	3.1 in (80 mm)	3.1 in (80 mm)
Length	27 in (686 kg)	18 in (457.2 mm)	25 in (633 mm)	34 in (863 mm)	10.3 in (262 mm)	7.2 in (183 mm)
Weight	12.8 lbs (5.8 kg)	33.4 lbs (15.1 kg)	78.3 in (35.5 kg)	152.2 lbs (69 kg)	18.3 lbs (8.3 kg)	9.9 lbs (4.5 kg)

Accessories



Sheet Handler - 8100361

- Remove high/low when aligning plate
- 100 times faster than using dogs and wedges
- Center Sheet Handler over the seam, turn Magswitch on, press to align and tack



Stiffener Alignment Tool - 8100554

- Mounts onto MLAY 1000x2 lifting magnet
- Provides stop for setting up stiffener beams
- Keeps beams at 90 degrees during fit-up



8100553



Beam Press Accessory - 8100553

- Attaches to MLAY 1000x4 or 1000x6 lifting magnet
- Provides pry point for fitting stiffener beams
- Easy-carry handle allows for transportation by one or two people



Heavy Sheet Leveler - 8100540

- Remove high/low during plate fit-up
- Levels up to 2" thick plate
- Easy-carry handle



8100361

LIFTING TOOLS & SYSTEMS

Changing The Way Material Lifting is done!

At Magswitch, our lifting tools are the solution for your heavy lifting, plate handling applications, sheet alignment and de-stacking sheets. Our tools eliminate time consuming handling of hooks and chains when you load and unload your burn tables. Unlike older technology, Magswitch lifters exert full hold on thinner steel. With numerous impressive features such as dual hook, single hook, replaceable pole shoes and more, Magswitch lifters are increasing productivity and safety in every workplace.



8100089



Customer Review **MLAY600 Lifting Magnet**

This was just what we were looking for. Good holding power and the right size for equipment disassembly on the shop floor. This cuts our time down significantly when performing planned maintenance repairs and adds a high level of safety to the operation.



8100482

Lifting Pipe with MLAY1000x6 Lifting Magnet



8100403

Lifting Steel with MLAY1000x3



8800487

Burn Tables with Hand Lifter 60 CE



8100549

Heavy Sheet Handling with MLAY1000x12

Heavy Lifters



FLAT



ROUND



IRREGULAR

*Requires Pole Shoes

Applications: Lifting, Infrastructure, Shipyards

Magswitch Heavy Lifters are built for heavy-duty lifting. Our magnetic technology is powerful without the need for a power source. The dual lift hook offers the stability to lift horizontally and a single hook to lift into a vertical position.

- Lock On and Off handle
- Superior hold force on thin steel (70mm deep field)
- Compact, lightweight and easy actuation
- Lifts large flat sheets, beams and pipe
- Performs well on air gaps such as rust and dirt
- Customizable pole shoes to fit almost any application
- Magnet turns completely On and Off
- Magnet stays clean as you can wipe off debris easily
- Does not require an electrical power source

MLAY600 Series

The Magswitch MLAY 600 series magnets are perfect for small materials and light to medium lifting. These lifters are lightweight, have a small profile and feature our full swivel hook for lifting from the top or the side. Each features a locking handle to ensure release of load is only intentional. With full field saturation, hold force at 0.5 in (12.7mm), these lifters are ideal for thinner steel, but hold thick steel just as well.

MLAY1000 Series

For heavy lifting, the MLAY1000 series lifters achieve full hold on approximately 1in (25.4mm) thick steel. These lifters feature our full swivel hook for lifting from the top or the side. Each lifter is manually activated and features a safety lock in both on and off position. The MLAY1000 series features a replaceable pole shoe, ideal for customizing to fit your application. With full field saturation (hold force) at 1.0in (25.4mm), this lifter is ideal for porous material and thick steel.

***Pole Shoes Available: MLAY600x2, MLAY600x4, MLAY 1000x2,3,4,6.**



	MLAY600	MLAY600x2	MLAY600x4	MLAY1000	MLAY1000x2	MLAY1000x3	MLAY1000x4	MLAY1000x6	MLAY1000x12
Part #	8100089	8100360	8100364	8100088	8100484	8100403	8100418	8100482	8100549
Max Breakaway (3:1 SWL)	195 lbs (89 kg)	341 lbs (155 kg)	750 lbs (340 kg)	333 lbs (151 kg)	668 lbs (303 kg)	913 lbs (414 kg)	1215 lbs (551 kg)	2034 lbs (922 kg)	4025 lbs (1826 kg)
Height	7.2 in (184 mm)	6.7 in (170.9 mm)	6.6 in (166.5 mm)	10 in (253 mm)	10.5 in (267.5 mm)	10.4 in (264.5 mm)	10.3 in (260.7 mm)	10 in (253.3 mm)	11.9 in (302 mm)
Width	2 in (51.5 mm)	6.5 in (165.4 mm)	6.5 in (165.4 mm)	2.8 in (71.5 mm)	7.7 in (195.6 mm)	7.7 in (195.4 mm)	7.7 in (195.4 mm)	7.7 in (195.4 mm)	12 in (306.8 mm)
Length	4.2 in (106 mm)	8.7 in (221 mm)	9.3 in (236 mm)	5.8 in (147 mm)	12.6 in (318.8 mm)	10.7 in (271.3 mm)	13.8 in (350.3 mm)	20.1 in (510.3 mm)	19.5 in (496 mm)
Weight	4.4 lbs (2 kg)	11.5 lbs (5.2 kg)	17.9 lbs (8.1 kg)	11.5 lbs (5.2 kg)	23.8 lbs (10.8 kg)	36.5 lbs (16.6 kg)	45.2 lbs (20.5 kg)	60.3 lbs (27.4 kg)	121.3 lbs (55 kg)



8100418

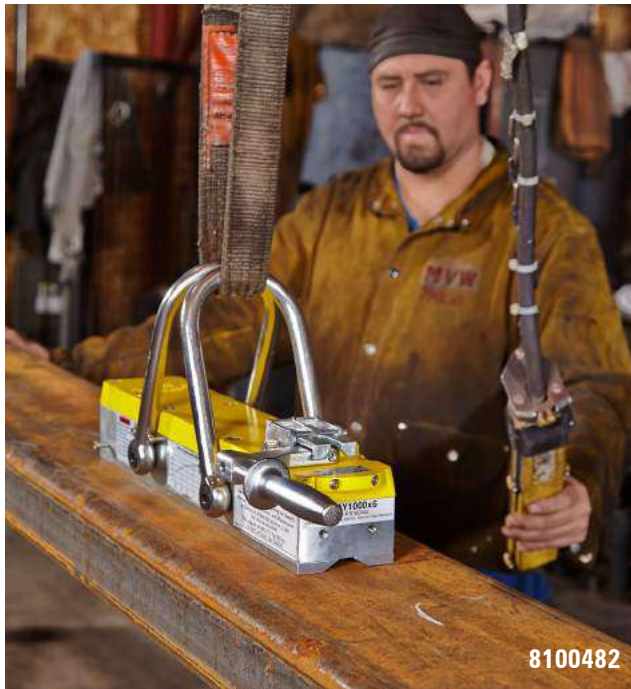

8100482



8100482

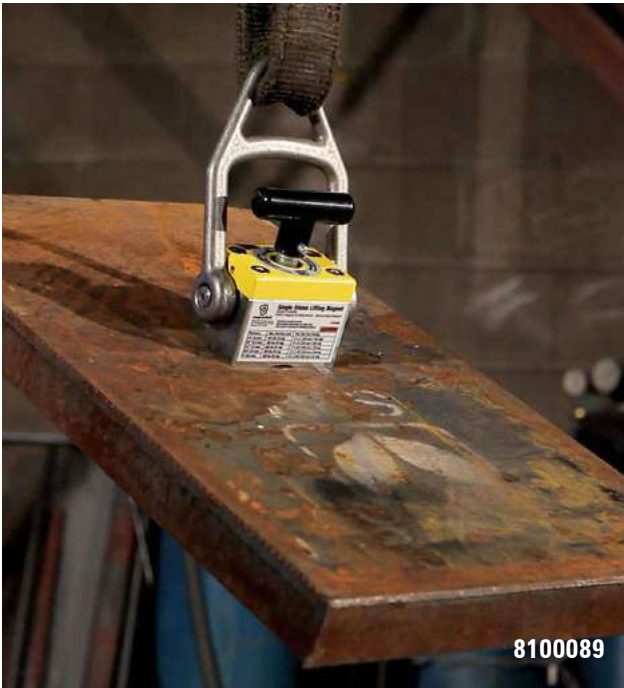

8100089



8100364

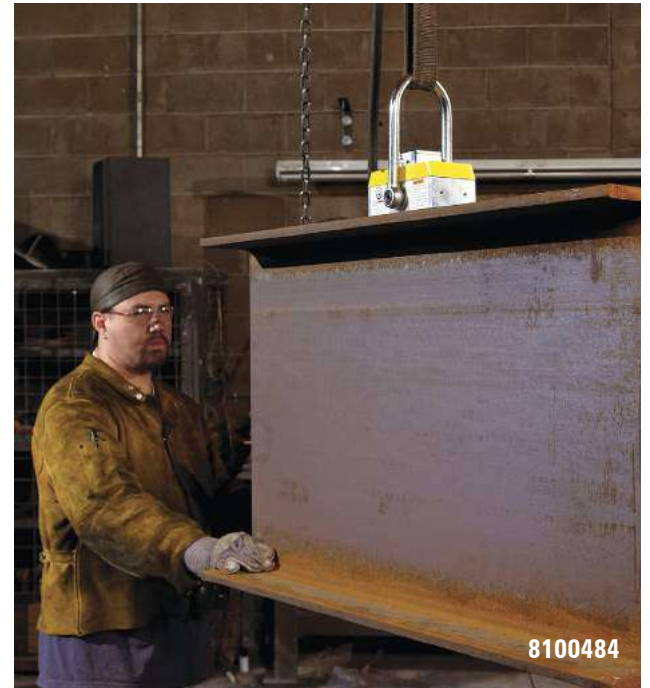

8100484

	MLAY600	MLAY600X2	MLAY 600X4	MLAY1000	MLAY1000X2	MLAY1000X3	MLAY1000x4	MLAY1000X6	MLAY1000X12
Part #	8100089	8100360	8100364	8100088	8100484	8100403	8100418	8100482	8100549
Max. SWL 3:1 Lift Capacity*	195 lbs (89 kg)	341 lbs (155 kg)	750 lbs (340 kg)	333 lbs (151 kg)	668 lbs (303 kg)	913 lbs (414 kg)	1215 lbs (551 kg)	2034 lbs (922 kg)	4025 lbs (1826 kg)
Thin Steel Working Load on 1/4" 3:1 Lift Capacity*	170 lbs (77 kg)	248 lbs (112 kg)	517 lbs (234 kg)	205 lbs (92 kg)	425 lbs (205 kg)	446 lbs (202 kg)	494 lbs (224 kg)	783 lbs (355 kg)	1331 lbs (603 kg)
Full Saturation	600 lbs (272 kg)	1100 lbs (498 kg)	2285 lbs (1036 kg)	1000 lbs (453 kg)	2000 lbs (907 kg)	2733 lbs (1239 kg)	3900 lbs (1769 kg)	6446 lbs (2923 kg)	12000 lbs (5443 kg)

*SWL (Safe Working Load) = $\frac{\text{Maximum Force}}{\text{Safety Factor (> 3)}}$

MAGSWITCH TECHNOLOGY

- Stability
- Lift to Shear
- Replaceable Pole Shoe

Stronger Hold on Thinner Material

OLD TECHNOLOGY

- Stability
- Lift to Shear
- Replaceable Pole Shoe



Weight:
58 Lbs



Weight:
85-130 Lbs

783 LBS	N/A	1/4"
1,298 LBS	900 LBS	1/2"
1,872 LBS	1,400 LBS	1"
2,148 LBS	2,000 LBS	2"

All ratings per ASME 3:1 Safe Working Load



FLAT

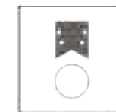

ROUND



IRREGULAR

Requires Pole Shoes

Pole Shoes available for the following lifters:
MLAY600x2, MLAY600x4,
MLAY1000x2, MLAY1000x3, MLAY1000x4, MLAY1000x6



Dual Hook: Stability Control

Use both hooks for safer lifts; the force of the lift stabilizes the magnet and reduces dangerous swings in the load

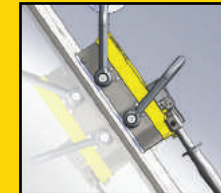

Single Hook: Lift from Horizontal to Vertical

Use one swivel hook when lifting from flat to vertical



Lock On/Lock Off Handle

Meets or exceeds all domestic and international lifting standards

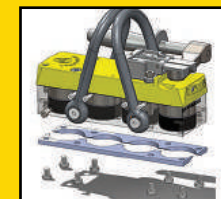

Replaceable Pole Shoes

Periodically replace the pole shoes to maintain safety and extend the life of the lifter

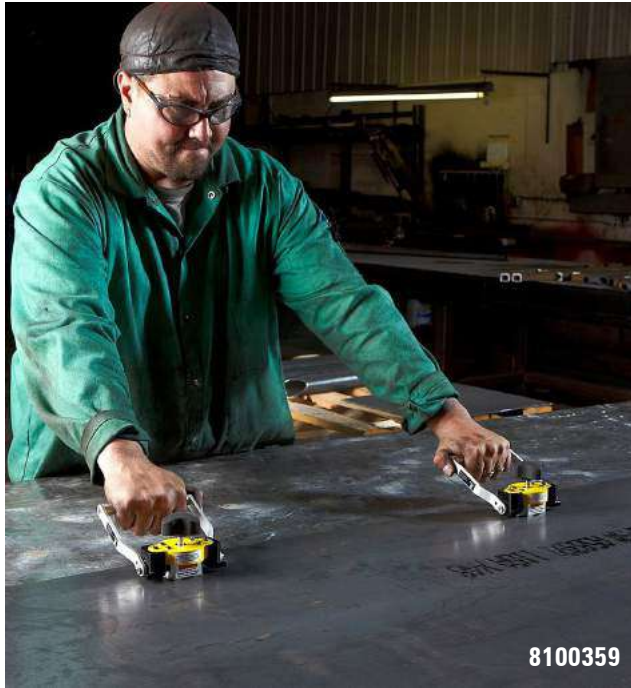

Hand Lifters



FLAT



ROUND

Single & Dual Hand Lifters

Magswitch Single and Dual Hand Lifters safely pick up hot, sharp or dirty steel with our strong magnets. An ergonomic fixed handle and a lever locking mechanism prevent accidental release.

- Holds flat and round surfaces of steel
- Lightweight and easy to use
- Shallow field magnets allow for de-stacking of thin material
- Adjustability range length allows for versatile uses
- Magnet turns completely On and Off
- Magnet stays clean as you can wipe off debris easily
- Does not require an electrical power source

Hand Lifter 60M

Magswitch Hand Lifter 60-M is a manual ON and OFF magnetic hand lifter great for dragging sheet and all your small steel handling needs.

- Holds flat and round surfaces of steel
- Pivot handle with multi settings (for sheet dragging) or locking handle vertical for use as a (hand lifter)
- Battery strength indicator light
- No need to manhandle steel or fight magnets in moving steel
- Magnet turns completely On and Off
- Magnet stays clean as you can wipe off debris easily
- Does not require an electrical power source

Hand Lifter 60CE

Our one-handed magnetic lifter delivers more control with the use of only one hand. Lift and release steel with just push of a button.

- Magnet turns completely On and Off at the push of a button
- Magnet stays clean
- Holds flat and round surfaces of steel
- 100% duty cycle-magnet can stay on forever
- Battery strength indicator light
- Recharges in 20 minutes
- Batteries have 2000 actuations per charge
- Includes charger and 2 rechargeable batteries
- Fail-safe technology



	Dual Hand Lifter 400	Dual Hand Lifter 235	Fixed Hand Lifter 400	Fixed Hand Lifter 235	Hand Lifter 60 M	Hand Lifter 60 CE
Part #	8100822	8100821	8100810	8100795	8100359	8800487
Max Breakaway	751 lbs (341 kg)	431 lbs (196 kg)	375 lbs (170 kg)	216 lbs (98 kg)	216 lbs (98 kg)	198 lbs (89.7 kg)
Height	5.2 in (133.3 mm)	4.4 in (111.4 mm)	5 in (127 mm)	4.1 in (105 mm)	5.5 in (140 mm)	5.3 in (134.6 mm)
Width	7.3 in (184.8 mm)	7.3 in (184.8 mm)	4.9 in (124.3 mm)	4.9 in (124.3 mm)	2.4 in (60 mm)	2.4 in (61 mm)
Length	23 in (583.8 mm)	23 in (583.8 mm)	6.9 in (175.4 mm)	6.9 in (175.4 mm)	5.3 in (134.3 mm)	5.3 in (134.6 mm)
Weight	6 lbs (2.7 kg)	4.2 lbs (1.9 kg)	2.4 lbs (1.1 kg)	1.5 lbs (0.7 kg)	1.6 in (0.7 kg)	2.4 lbs (1.1 kg)

Heavy Lift Frames

If you lift pipe, I-beams or heavy sheet steel, this is a tool you need in your shop! Magswitch Technology is “Changing the way things are done” once again by introducing the innovative new Heavy Lift Frame Series. This game-changing tool utilizes patented shallow-field technology to lift a single sheet from a stack of material. Enhanced workplace safety is achieved through fail-safe operation, increased strength, efficiency and durability. By providing unique magnetic solutions for new standards of productivity, one man can easily do the work of two!

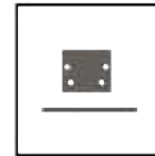

FLAT

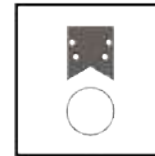

ROUND

Faster, Strong & Safer!

- Patented, powerful shallow-field technology
- Revolutionary in steel lifting / handling
- Scalable technology – customized to meet your needs
- Add additional magnets as needed
- Cordless electric (CE) actuation with remote control allows for easy ON/OFF capability (Available on most heavy lift frames)
- Single sheet de-stack capability
- Onboard battery creates a more compact tool
- Enhanced workplace safety is achieved through fail-safe operation
- Dual Purpose – under hook or forklift
- Benefits include Increased productivity, safety and significant cost savings



8800432



HLF-8000-M with (3)MLAY1000x12

	HLF-8000-M 2 Tool 2 Ton Lifter	HLF-8000-M 3 Tool 3 Ton Lifter	HLF-8000-M 4 Tool 4 Ton Lifter	HLF-8000-M 5 Tool 1 1/2 Ton Lifter
Part #	8800431	8800432	8800596	8800468
Max Breakaway	4000 lbs (1818 kg)	6000 lbs (2727 kg)	8000 lbs (3629 kg)	3000 lbs (1364 kg)
Height	22.5 in (571.5 mm)	22.5 in (571.5 mm)	22.5 in (571.5 mm)	19 in (483 mm)
Width	30.5 in (774.7 mm)	30.5 in (774.7 mm)	30.5 in (774.7 mm)	48 in (1219 mm)
Length	116 in (2946.4 mm)	116 in (2946.4 mm)	116 in (2946.4 mm)	72 in (1829 mm)
Weight	400 lbs (181.4 kg)	460 lbs (208.7 kg)	520 lbs (236 kg)	450 lbs (204 kg)



(6)MLAY600x4 with Cross Beams



**ELAY1000x6
Electric Lifter**

Safety is our #1 Priority!



*** Product available in black**

NEW



TO MAGSWITCH

Electric ELAY Lifting Series!

Magswitch is excited to introduce our brand NEW electrically actuated lifter designed with safety in mind! The ELAY series features smart tool technology that will change the way how lifting steel is done! Join the Magswitch revolution!

- Variable Field Output (VFO)
- De-Stack Thin Steel
- 48 Volt DC
- Smart Tool Technology
- Fail-Safe
- No backup battery required
- Power Disconnected – Part stays on!
- Easy button lift and de-stack
- Control Protocol: CANopen
- Pole shoes included. Custom options available
- Different electric lifter sizes coming soon to Magswitch!

Part #	81401247
Max Breakaway	6101 lbs (2768 kg)
Thickness De-Stack	Configurable with VFO
Mount Options	Dual Swivel Hoist Rings
Weight	130 lbs (59 kg)



Heavy Lifting Solutions

Combining the patented Magswitch Technology with plate handling systems, Heavy Lifting Solutions has the answers for your plate handling applications. Eliminate time consuming handling of grabs and chains when you load and unload your burn tables. From manual systems to fully integrated robotic systems, Application Engineers will work side by side with the Magswitch team from design phase to project completion.

Have a Heavy Lifting Solution?

Contact our Application Engineering Team at heavyliftingsolutions@magswitch.com or visit us magswitch.com/heavyliftingsolutions or call us at +1 (303) 468.0662

Custom Lifting Solutions

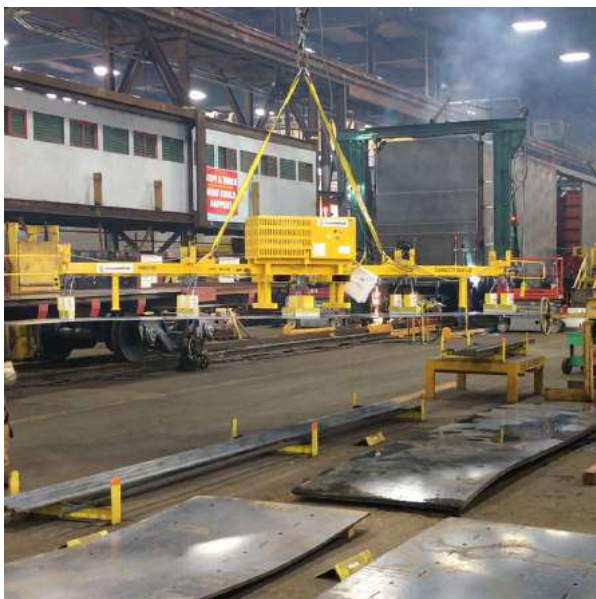

Custom Lifting Application at Gunderson Marine

From small plate applications (4'x8', 5'x10' & 6'x12') to large (8' to 10' x 15' to 60') and to thin material as low as 12 gauge, we will custom design a solution to your specific application.

RetroFit Lifting Solutions

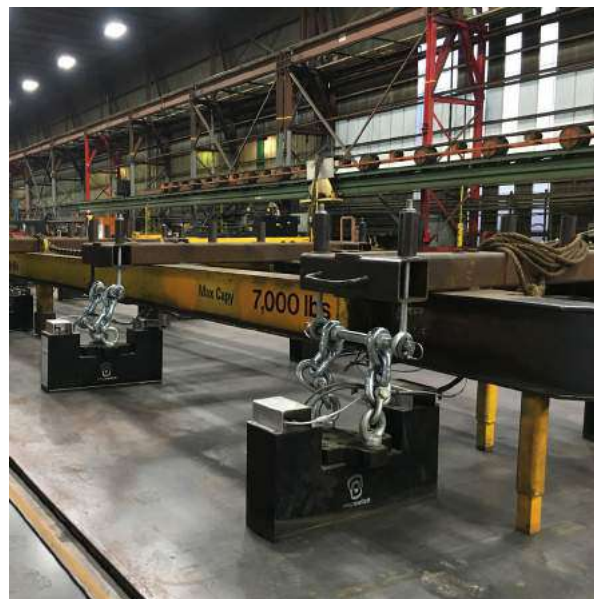

Retrofit Application at Gunderson Marine

If you have a custom application or an odd problem that needs a solution, Magswitch lifters can be adapted to existing spreader bars and retrofitted to keep conversion costs down.

Ergonomic Lift Assist



Press Brake Application at Buyer's Products

Where physical stress due to manually lifting and positioning becomes an issue, Magswitch offers ergonomic material handling equipment that is designed and built to fit each specific application. With safety the most important goal, workplace productivity and efficiency is maximized with each design.



The Magswitch Advantage

Safety

Our lifters are designed to be 'fail safe' since there is no need of any power during a lift. With positive indication of magnetic circuit, operator can confidentially perform lift knowing the plate is fully attached. Magswitch offers Electric, Pneumatic or Manual for 'on-off' actuation.

Performance

Magswitch technology applies maximum hold force at shallow depths enabling consistent strong hold force on thin and thick steel. Our products give consistent, powerful results. 1/3rd the magnet weight of our competitors.

Flexibility

Magswitch products has flexible options to handle your lifting needs & adapt to odd or round shapes.

Downtime

Downtime with Magswitch is eliminated unlike traditional steel lifting systems. With a 100% duty cycle, no more standing or waiting around.

Cost Savings

Electromagnetic and vacuum lifting systems are costly in the long term when it comes to energy and maintenance costs. Magswitch 'greentech' technology will offer you significant savings in energy and repairs while increasing productivity.

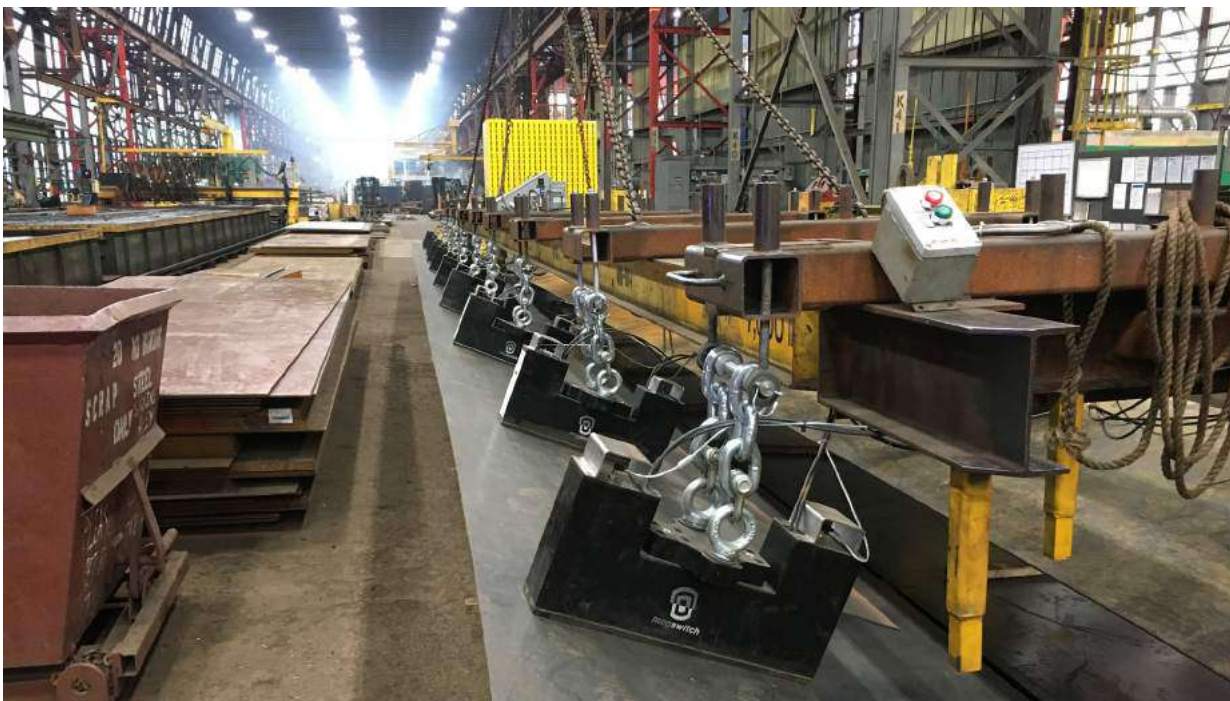

WOODWORKING

With Magswitch patented magnetic technology, we have created woodworking products & tools that make projects faster, easier to use and safer. Our workholding system built around Magswitch ON/OFF magnetic clamps provides strong, precise placement anywhere on any steel table. Our product line includes universal featherboards, jigs, mounts and squares for safe and precise workholding. Our award-winning technology is a breakthrough for accomodating your workholding needs on all your power tool tables including table saws, joiners, planers, band saws and shapers.

Product Lineup

- Woodworking Starter Kit
- Universal Mounting Base
- Featherboards
- MagJigs
- Guides
- Tracks



8110015



Customer Review *Universal Featherboard*

The versatility of the featherboard is its best quality, and the magnets, though appearing undersized, are more than adequate to perform. Delighted with the purchase.

Changing The Way Woodworking is done!



8100328

Anti Kickback with Pro Table Featherboard



8110005

Custom Hold-Down with MagJigs



8110131

Anti Kickback with Reversible Featherboard



8110125

Sanding & Facing with Resaw Guide

Woodworking Starter Kit



8110134

Vertical Featherboard W/ Risers



8110178

Universal Mounting Base



8110112

A perfect entrée into the Magswitch Workholding System. Once you have this tool, get all the other great tool attachments and simply mount to the base as needed.

The Starter Kit comes with:

- Reversible Featherboard Attachment
- Universal Mounting Base
- (2) MagJig 150's.

Our Vertical Featherboard adds a dimension of dual plane workholding. For use with the Woodworking Starter Kit and the Pro Table Featherboard. In the Magswitch Workholding System, it mounts to the Reversible Featherboard Attachment, Universal Mounting Base and MagJigs, each sold separately.

The Universal Mounting Base is the centerpiece of the Magswitch Workholding System. Simply add the desired tool attachment, place on any steel or cast-iron tabletop, and you are ready to go. Additional tool attachments on next page are designed to fit the Universal Mounting Base, each sold separately.



8110328



8110178



8110134



8110362

Pro Table Featherboard



8110328

Our woodworking featherboard table is perfect for vertical and right side applications. Push the flexible fingers against the workpiece and twist each knob to turn On/Off easily and quickly.

Reversible Featherboard



8110131

Our sturdy yet lightweight woodworking featherboard is reversible for left and right hand feeds. Perfect for infeed and outfeed applications. Accomodates the Vertical Featherboard attachment and the Woodworking Starter Kit, sold separately.

Universal Featherboard



8110015

Designed to work on any cast-iron table to hold down your work so you don't have to. It works on both sides of the blade and even the fence. It features two 20mm Magswitch MagJig 95 magnets.

Ultimate Thin Stock Jig



8110362

Our thin stock jig features a stepped side for most common sizes and a fixed roller bearing and extends forward for accurate repetitive ripping. Ideal for thin stock hold down or infeed/outfeed a table saw. Requires Woodworking Starter Kit, sold separately.

Dual Roller Guide



8110130

Our dual roller guide has a dual set of roller bearings to firmly support the smooth gliding of wood through a blade. Requires our Woodworking Starter Kit and mounts to the Universal Mounting Base and MagJigs, sold separately.

Resaw Guide



8110125

Our resaw guide is designed with an angled infeed/outfeed to allow for blade drift adjustment. The roller bearing provides support and smoothly glides wood through a blade. Requires a Woodworking Starter Kit, sold separately.

18" Universal Track



8110132

Easily and quickly set up a fence anywhere on a steel table. The track is aluminum and solid for heavy duty jobs. Make your own jigs, fixtures, stops, fences, zero clearance fences! Requires a Woodworking Starter Kit, sold separately.

36" Universal Track



8110370

Easily and quickly set up a fence anywhere on a steel table. The 36-inch track is aluminum and solid for heavy duty jobs. Make your own jigs, fixtures, stops, fences, zero clearance fences. Requires a Woodworking Starter Kit, sold separately.

MagJigs

Applications: Woodworking, Fixturing, Clamping, Welding

Magswitch MagJigs are a fixturing clamp that will easily secure your fixture into place. Rotate the knob to turn on and off for magnetic hold force. With the Magjig, simply drill a hole in a fixture and place the MagJig in to use for downward pressure clamping.

- Holds flat and round surfaces of steel
- 3/4" standoff for flush mount
- Designed with screw holes to add more security in a fixture
- Excellent for woodworking, welding, and fabrication
- Magnet turns completely On and Off
- Magnet stays clean
- Does not use an electrical power source



FLAT



ROUND

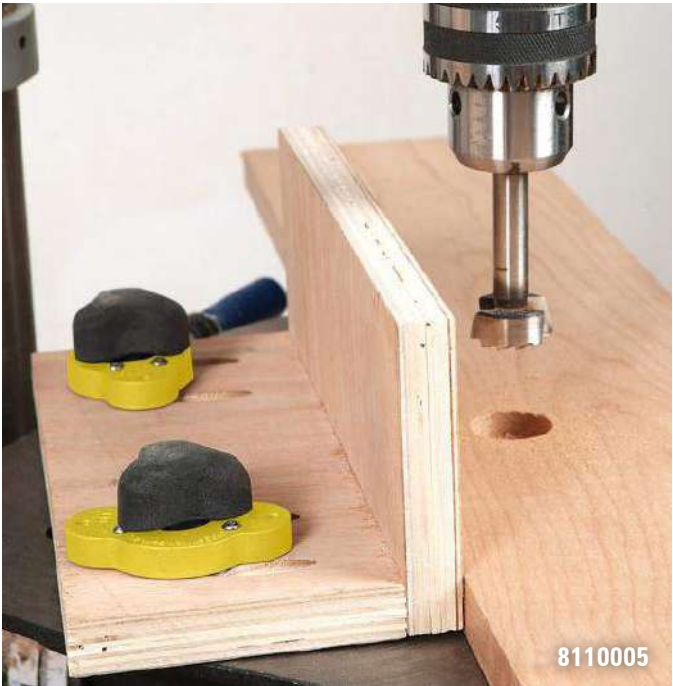

8110005

 Interested in Custom Products? Refer to Pg 35 for more info!



	MagJig 235	MagJig 150	MagJig 95	MagJig 60	MagJig 60 Keychain
Part #	8100377	8110005	8110004	8100818	8100514
Max Breakaway	235 lbs (106 kg)	150 lbs (98 kg)	95 lbs (43 kg)	60 lbs (27 kg)	60 lbs (27 kg)
Height	3.1 in (78.3 mm)	2.1 in (52.1 mm)	1.8 in (46.6 mm)	1.7 in (43 mm)	1.7 in (43 mm)
Width	2.4 in (60 mm)	1.7 in (44 mm)	1.3 in (34 mm)	1.1 in (26.8 mm)	1.1 in (26.8 mm)
Length	3.5 lbs (67 kg)	2.6 in (67 mm)	2.2 in (57 mm)	1.6 in (39.5 mm)	1.6 in (39.5 mm)
Weight	1.1 lbs (0.5 kg)	0.2 lbs (0.1 kg)	0.2 lbs (0.1 kg)	0.2 lbs (0.1 kg)	0.2 lbs (0.1 kg)



8110015

Custom Products

Magswitch Technology provides custom product solutions. We provide a whole range of expertise from design engineering, manufacturing, and marketing. Combining our technology with professional expertise, we can create specialized products that fit your needs, and budget.



Have a Custom Product?

Contact our Application Engineering Team at customproducts@magswitch.com or visit us magswitch.com/customproductsolutions or call us at +1 (303) 468.0662

Private Label

Collaborative design and complete manufacturing of private label products utilizing Magswitch Technology.

Co-Branded

Strategic partnership with other businesses for development, manufacturing, and marketing of products utilizing Magswitch Technology.

Custom Solutions

If you have a custom application or an odd problem that needs a solution, Magswitch's Application Engineering team will work with your from concept to final delivery and follow up.

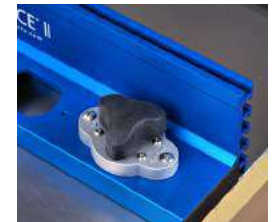

The next generation Carter MAGFENCE® II, magnetic fence takes quick attachment, release and adjustment to the next level of simplicity. With the addition of simple on-off switchable magnets the MAGFENCE® II easily attaches to most ferrous metal tables regardless of size. The switchable magnets allow instant and powerful magnet force to be applied to hold the fence firmly in place for any cutting, drilling, positioning or alignment need, then just as easily switched off for instant adjustment or removal. Because there is no direct to table mounting required, the Carter MAGFENCE® II is universal to any size table.





MAGFENCE® II
by Carter Products



MoonRay 3D
Printer by
SprintRay

The Magswitch ***Competencies***

Design & Engineering

- Magnetic Circuits
- ANSYS Mechanical
- ANSYS Maxwell – Magnetics
- Electric Motors
- Pneumatic Actuators
- Gearbox Design
- Hydraulic Actuators
- Spring Design
- Design for Manufacturing / Assembly
- Structural Design
- Analytical Thinking
- Weld Grounding
- Extreme Temperature Design
- Engineering Standards
ASME, ISO, ANSI, CE, EC

Operations

- Product Development
- Product Testing
- Product Packaging
- Product Distribution

Marketing & Communications

- Marketing Materials
- Social Media Integration
- Cross Promotions
- White Paper/Press Release

Application Services

Our Application Engineering team at Magswitch Technology strives to provide you all the information and support to create a custom product from development to delivery. Our application services include collection of data and evaluation, detailed proposal, custom edge analysis, accessory and pole shoe suggestions, safety factor analysis, contract manufacturing and distribution and much more!



Interested in Custom Products? Refer to Pg 31 for more info!
Interested in Heavy Lifting Solutions? Refer to Pg 25 for more info!



Custom Lifting Gunderson Marine



Gunderson found a resolution in new magnets from Magswitch Technology. By using the same technology that it uses in the robotic business, Magswitch was able to retrofit the existing tool frame, reducing changeover time and helping Gunderson squeeze more productivity out of its plasma cutting operations.

Application Engineering Process



Phase 1: Collection of Application Details & Initial Evaluation

The 6 critical elements to selecting a tool are Material Grade – e.g. AISI 1020, Thickness, Weight, Shape, Surface Condition - e.g. coatings, treatments, roughness and Motion Profile.

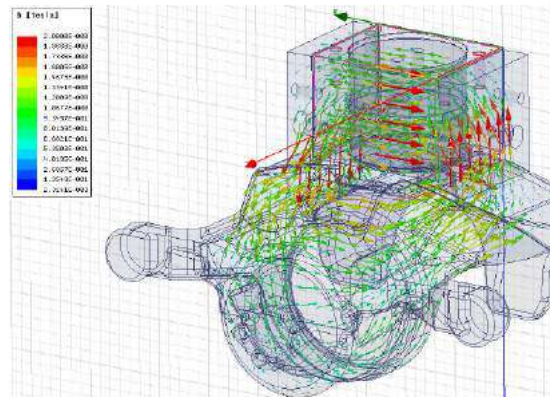

Phase 2: Detailed & Customized Proposal

The detailed proposal includes the overview of application details, tool selection, tool placement on target component, pole shoe design suggestion if necessary, accessory design suggestion, ANSYS magnetic FEA analysis if required, and breakdown of safety factor analysis.



Phase 3: Final Design & Delivery

After selecting Magswitch as the specified tool for the application, Magswitch engineers will complete detailed designs for pole shoes and accessories in order to produce and deliver components to meet project timelines.



Cutting Edge Analysis

In addition to application design assistance, Magswitch offers ANSYS magnetic analysis to confirm holding force and validate pole shoe designs. Magswitch prides itself on having one of the most knowledgeable distribution networks and a team of engineers to handle any application presented. It is highly recommended that you contact your local distributor for application assistance on every project. Many factors determine the performance of a magnet and all should be accounted for before selecting your tool.

Contract Manufacturing & Global Distribution

We're not only experts in magnet technology, we also are experts in manufacturing and distribution of components that do not involve magnets. We specialize in manufacturing of complete custom products using common materials and manufacturing processes. Our application engineers will work with you from the concept design all the way to final product delivery and after-sales service.

Need Support?

For Custom Products Support

customproducts@magswitch.com

or visit us magswitch.com/customproductsolutions

For Heavy Lifting Solutions

heavyliftingsolutions@magswitch.com

or visit us magswitch.com/heavyliftingsolutions



Magswitch Automation

Offering unique capabilities and significant improvements to end of arm tooling, pick-and-place, body-in-white and many other applications, the powerful and lightweight tools in our automation line make it possible to implement magnets where they weren't previously applied. Magswitch can replace vacuum cups and traditional pin clamps which impact operating costs through high energy consumption and downtime.

Magswitch is rapidly being deployed as a platform technology by major automotive OEMs and Tier One suppliers including VW, Audi, GM, Gestamp and Magna among others. Like these companies, if you handle or fabricate steel using automation, you will find solutions and savings with Magswitch that you never knew were possible.

Applications

- Assembly
- Bin Picking
- Pressure Vessel Fabrication
- Machine Tending
- Stamping/Press Line
- Ergo Lifting
- & much more...

Products in this lineup

- E Series
- J Series
- T Series
- AR Series
- LAY Series
- AY Series
- Sheet Fanner Series

Have a custom application?

Magswitch Technology provides Custom Automation Solutions. We provide a whole range of expertise from design, engineering, manufacturing all the way to delivery, follow up and marketing. Combining our technology with our expertise, we can create specialized products that fit your needs and budget!

Contact our Application Engineering Team at
applications@magswitch.com
or call us at +1 (303) 468.0662

*Want more information on Automation? Find our Automation catalog
Online: www.magswitch.com/catalogs
Call: +1 (303) 468.0662*

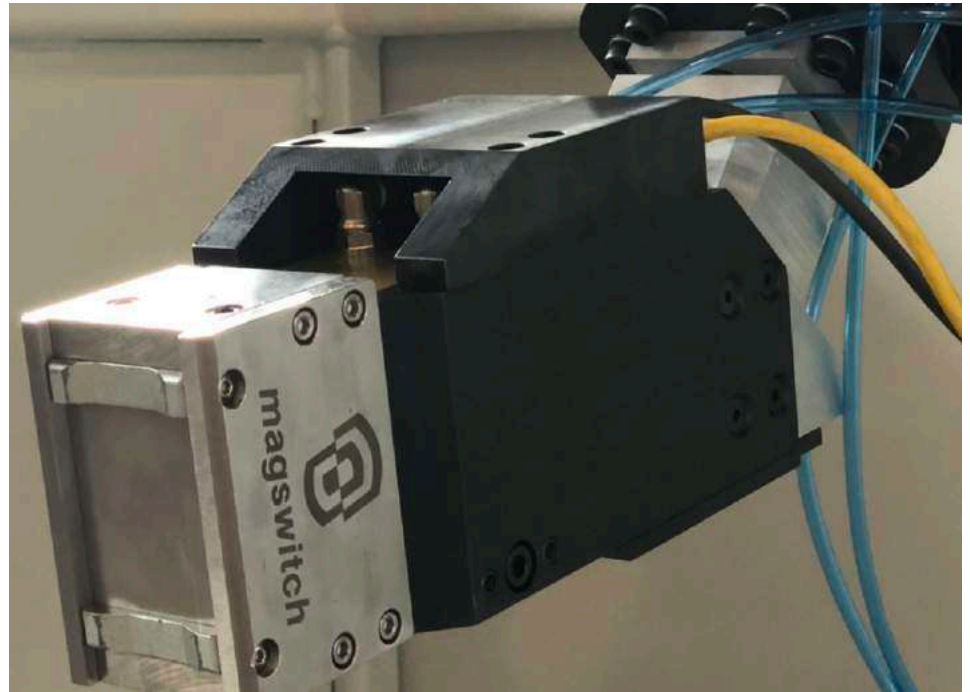
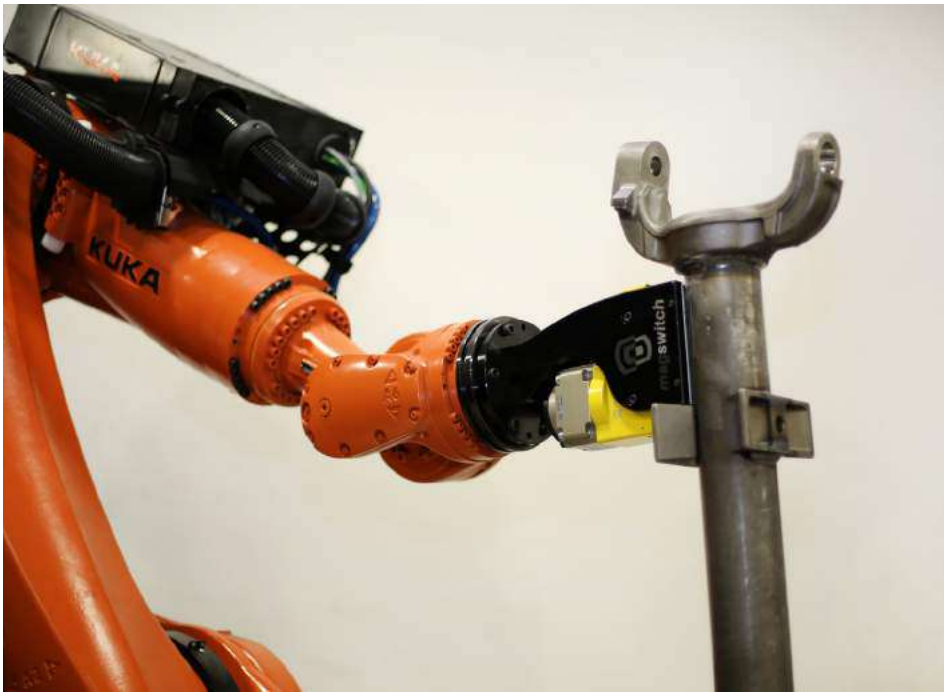
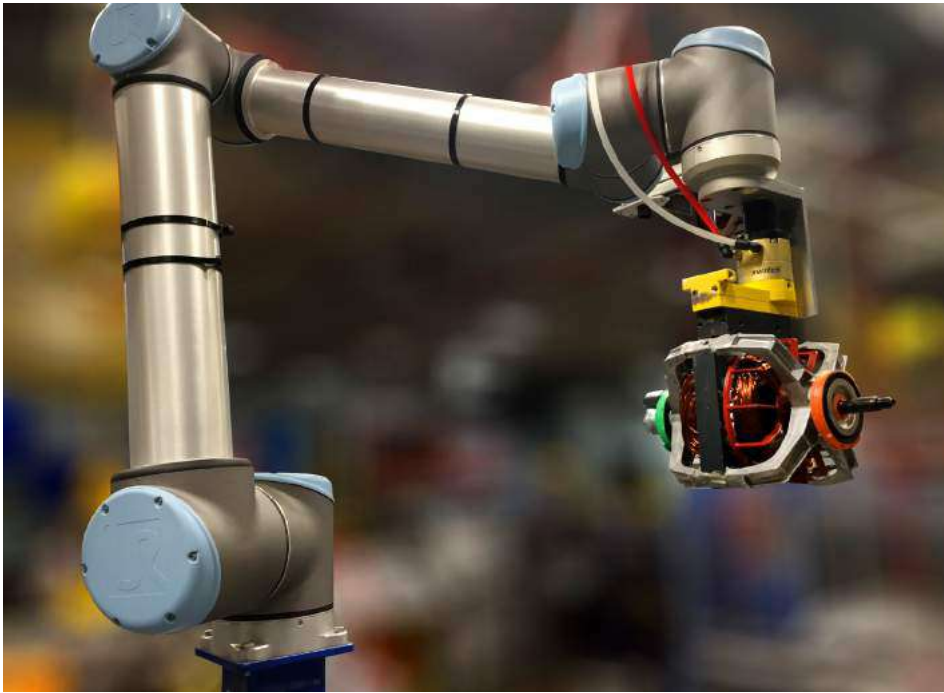

Get In Touch!

magswitch.com

Colorado, USA

Magswitch Headquarters
1355 Horizon Avenue,
Lafayette, Colorado 80026
Ph: +1 (303) 468.0662

Michigan, USA

Magswitch Automation Office
29445 Beck Road, Suite A-108
Wixom, Michigan 48393
Ph: + 1 (303) 468.0662

Ingolstadt, Germany

Magswitch Europe Office
Marie-Curie-Str. 12
Ingolstadt, Germany 85055
Ph: +49 (175) 1668723

Shanghai, China

Magswitch Asia Office
Room 329#, 3rd Floor
No. 83, Fumin Road, Jufu Building
Jingan District Shanghai, China 200040
Ph: +86 (137) 3809 5834



Why are Magswitch colors yellow?

In 2005, Magswitch decided to support a junior cycling team. With safety in mind, team jerseys were made yellow to make sure the riders can be easily seen on the roads. In 2007, when Magswitch created its image and colors for our tools, yellow was again the obvious choice given our commitment to safety with our tools all over the world. As a result, we launched our new safety logo in the spirit of our commitment to making your workplace safe.



Customer Service: cs@magswitch.com

Marketing: marketing@magswitch.com





Heavy Lifting Solutions: heavyliftingsolutions@magswitch.com

Custom Products: customproducts@magswitch.com

Automation Solutions: applications@magswitch.com



Connect with Magswitch!

-  @Magswitch
-  @Magswitch_Tech
-  @Magswitch_Tech
-  c/MagswitchTechnology





Magswitch Headquarters

1355 Horizon Avenue,
Lafayette, Colorado 80026
Ph: +1 (303) 468.0662

Magswitch Europe Office

Marie-Curie-Str. 12
Ingolstadt, Germany 85055
Ph: +49 (175) 1668723

Magswitch Automation Office

29445 Beck Road, Suite A-108
Wixom, Michigan 48393
Ph: + 1 (303) 468.0662

Magswitch Asia Office

Room 329#, 3rd Floor
No. 83, Fumin Road, Jufu Building
Jingan District Shanghai,
China 200040
Ph: +86 (137) 3809 5834

magswitch.com

